

Power Transistor Test Sockets for T0-220, T0-3P

Low Insertion Force

DC30A or AC1000V

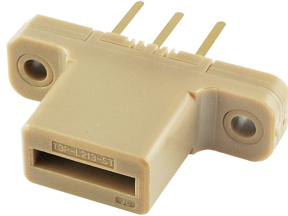

Materials

Body : Peek etc.

Contact : Copper Alloy, Au plating over Ni plating

Specifications

Mating Durability : 10,000 cycles (note*)

Contact Resistance : 20 mΩ max

Rating Current : DC30 A at 25°C

Insulation Resistance : 500 MΩ min

Withstanding Voltage : DC1500V 1 minute, AC1000Vrms 1 minute at 25°C

Temperature Range : -55°C~+150°C

note* : Using a Standard Test Lead of ours

- For a Test of Power Transistors, Thyristors and other discrete devices.
- Kelvin Contact type
- Suitable for packages including T0-220, T0-3P, T0-66, T0-247, T0-254, T0-262, T0-264.
(Some package might not be usable. Please call us)

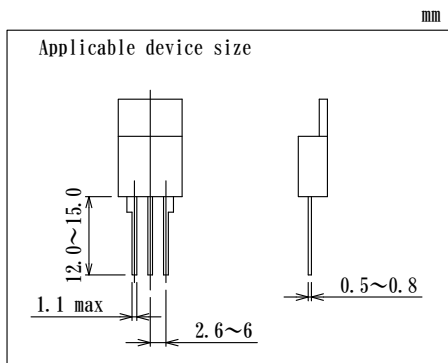

T3P-L213-ST

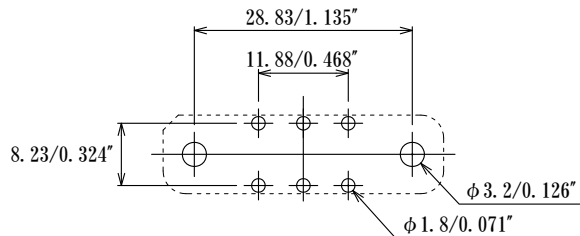
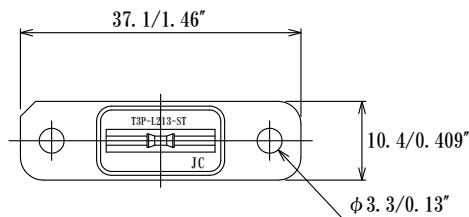

PC Board dimension

